

- IT** INSTALLAZIONE PANNELLO PORTA SYNTESIS® LINE BATTENTE
- DE** INSTALLATION TÜRBLATT SYNTESIS® LINE BATTENTE TÜRFLÜGEL
- GB** SYNTESIS® LINE BATTENTE HINGED DOOR INSTALLATION
- PL** MONTAŻ SKRZYDŁA W OŚCIEŻNICY ALUMINIOWEJ SYNTESIS® LINE BATTENTE
- PT** INSTALAÇÃO PAINEL PORTA SYNTESIS® LINE BATTENTE
- RU** УСТАНОВКА ПАНЕЛИ ДВЕРИ SYNTESIS® LINE BATTENTE
- CZ** INSTALACE DVEŘNÍHO KŘÍDLA SYNTESIS® LINE BATTENTE
- RO** INSTALARE PANOU DE UȘĂ SYNTESIS® LINE BATTENTE
- SK** INŠTALÁCIA DVERNÉHO KRÍDLA NA SKRYTÚ ZÁRUBŇU SYNTESIS® LINE BATTENTE
- SI** NAMESTITEV VRATNEGA KRILA SYNTESIS® LINE BATTENTE - KRILNA
- ES** INSTALACIÓN PANEL PUERTA SYNTESIS® LINE BATTENTE
- HU** SYNTESIS® LINE BATTENTE AJTÓSZÁRNY PANEL BESZERELÉSE
- NL** INSTALLATIE VAN DE SYNTESIS® LINE BATTENTE DRAAIDEUR
- HR** INSTALACIJA VRATNOGA KRILAN SYNTESIS® LINE BATTENTE - ZAOKRETNIA
- FR** INSTALLATION DU PANNEAU DE PORTE BATTANTE SYNTESIS® LINE BATTENTE
- FI** SYNTESIS® LINE BATTENTE SARANOIDUN OVILEHDEN ASENNUS
- TR** SYNTESIS® LINE BATTENTE MENTEŞELİ KAPI PANELİ MONTAJI

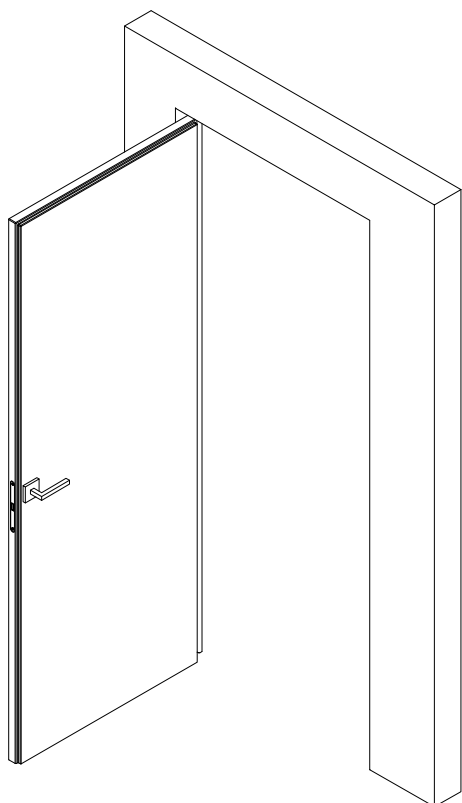



IT

Seguire attentamente le istruzioni.
Per un corretto montaggio, utilizzare utensili adatti come indicato e, per una corretta ergonomia, eseguire gli assemblaggi su supporti adeguati.
Alcune parti dei componenti possono avere delle superfici appuntite.
E' necessario quindi utilizzare adeguati dispositivi di protezione e proteggere le zone di lavoro.
"ECLISSE srl", non si assume alcuna responsabilità per danni derivati dall'uso non conforme alle presenti istruzioni.

Tutti i componenti del controtelaio sono testati e controllati in "ECLISSE srl"

GB

If you follow carefully these instructions for the assembly and installation process your life will be easier!
A pair of tressles are very useful when assembling the frames.
Some parts may have sharp edges so use gloves and be careful when handling the parts.

All Eclisse products are fully inspected and tested before they leave the factory.

BR

Seguir atentamente as instruções.
Para uma instalação correta, utilize ferramentas apropriadas conforme as instruções e, para uma ergonomia adequada, efetue as instalações utilizando suportes adequados. Algumas partes dos componentes podem ter superfícies cortantes, portanto é necessária a utilização de equipamentos de proteção adequados e é preciso proteger as áreas destinadas à execução dos trabalhos.
"ECLISSE srl", não assume qualquer responsabilidade por danos resultantes da utilização e execução que não estejam de acordo com estas instruções.

Todos os componentes do caixilho/sistema embutido são testados e controlados na "Eclisse srl"

PT

Postupujte pozorně dle pokynů.
Pro správnou instalaci používejte vhodné nástroje a s ohledem na bezpečnost práce používejte vhodné pracovní pomůcky. Některé vyrobené části mohou obsahovat ostré prvky. Proto je nutné používat odpovídající ochranné pomůcky a chránit pracovní místa. "ECLISSE srl" neodpovídá za žádné škody vyplývající z nedodržení návodu na montáž.

Všechny komponenty stavební zárubně jsou testovány a kontrolovány v "ECLISSE srl".

CZ

SK

Dôsledne dodržiavajte návod na montáž.
Pri montáži používajte uvedené náradie.
Kvôli správnej ergonómii a bezpečnosti pri práci odporúčame použiť montážne podpery.
Niektoré diely môžu mať ostré hrany.
Používajte ochranné pracovné prostriedky.
„ECLISSE srl.“ nezodpovedá za škody spôsobené nedodržaním návodu na montáž.

Všetky komponenty puzdra sú testované a kontrolované v „ECLISSE srl.“.

ES

Seguir las instrucciones con atención.
Para un montaje correcto, utilizar las herramientas indicadas, y para una correcta funcionalidad, ensamblar en los soportes adecuados.
Algunas partes del producto pueden contener superficies punzantes y/o cortantes.
Se necesita utilizar dispositivos de protección adecuados y proteger los espacios de trabajo.
"Eclisse SRL" no asume responsabilidad alguna por los daños derivados en la utilización no conforme a estas instrucciones.

Todos los componentes del contramarco están testados y controlados en "ECLISSE SRL".

NL

Volgt u deze instructies nauwkeurig.
Gebruik voor een correcte montage geschikt gereedschap, zoals aangeraden.
Voor een correcte werkhouding adviseren wij met schragen te werken.
Sommige delen van de verschillende onderdelen kunnen scherpe kanten hebben, daarom is het noodzakelijk om de juiste bescherming te dragen en de werkruimte te beschermen.
"ECLISSE srl" is niet aansprakelijk voor schade die ontstaan is door het niet opvolgen van deze instructies.

Alle delen van het frame zijn volledig geïnspecteerd en getest door "ECLISSE srl".

FR

Suivre scrupuleusement les instructions
Afin de réaliser un assemblage correct, choisir un support adapté et utiliser les outils appropriés comme indiqué sur la notice.
Quelques éléments du produit peuvent avoir des parties pointues ou coupantes, il est donc nécessaire d'utiliser des protections corporelles efficaces et sécuriser l'espace de montage.
ECLISSE décline toute responsabilité pour tous dommages provoqués par le non respect de ces règles.

Tous les composants du produit sont testés et vérifiés par ECLISSE SRL.

○

Folgen Sie genau der Montageanleitung
Für die korrekte Montage, verwenden Sie die angegebenen passenden Werkzeuge. Für die korrekte Ergonomie, sollten die Montagearbeiten auf passende Arbeitsflächen ausgeführt werden.
Einige der Bauteile können spitze Oberflächen haben. Es ist notwendig passende Schutzvorrichtungen zu verwenden und die Arbeitsfläche schützen.
„Eclisse Srl“ übernimmt keine Verantwortung für Beschädigungen, die durch Nichtbeachtung der Montageanleitung hervorgerufen werden.
Wandöffnung nach DIN 18183-1 erstellen
Alle Bauteile des Einbaukastens wurden in „Eclisse“ geprüft und getestet.

PL

Postępować zgodnie z instrukcją montażu.
W celu wykonania prawidłowego montażu, używać odpowiednich narzędzi, zgodnych ze wskazaniami, a dla zapewnienia odpowiedniej ergonomii pracy przy dokonaniu montażu stosować odpowiednie podpory. Powierzchnia niektórych elementów składowych może być ostra. W związku z tym koniecznym jest stosowanie odpowiednich środków ochrony indywidualnej oraz zabezpieczenie obszaru pracy. Eclisse SRL uchyła się od poniesienia jakiegokolwiek odpowiedzialności za poniesione szkody wynikające z postępowania niezgodnego z niniejszą instrukcją.

Wszelkie części składowe asortymentu Eclisse SRL są testowane w wewnętrznym laboratorium.

RU

Пожалуйста, строго следуйте инструкциям.
Для правильной установки пользоваться соответствующим оборудованием как указано, для правильной эргономики сделать монтаж на надежных основах. Некоторые части могут иметь заостренные концы, в связи с чем следует использоваться соответствующим предохранительным устройством и защитить рабочую зону.
«ECLISSE srl» не несет ответственности за ущерб, ставший следствием несоблюдения правил, содержащихся в данной инструкции.

Все компоненты пенала проходят необходимую проверку в фирме «"ECLISSE srl"».

RO

Urmați cu atenție instrucțiunile de montaj.
Pentru un montaj corect, folosiți ustensile potrivite, iar pentru o ergonomie adecvată, asamblarea se face pe suporturi corespunzătoare, urmând metodele indicate. Unele părți ale componentelor pot avea suprafețe ascuțite.
Prin urmare, este necesar să se folosească echipamente de protecție și să se asigure zona de lucru.
ECLISSE EST SRL nu își asumă nici o responsabilitate pentru daunele survenite ca rezultat al nerespectării prezentelor instrucțiuni.

Toate componentele din structura cadrului metalic sunt testate și controlate în fabrică.

SI

Če boste pazljivo prebrali in upoštevali dana navodila za sestavo in montažo podboja bo bistveno enostavneje.
Priporočljiva je uporaba rokavic zaradi morebitnih ostrih robov in previdno rokujte z izdelkom.

Vsi Eclisse izdelki so pod stalno kontrolo in testirani preden zapustijo tovarno.

HU

Az összeszerelésnél figyelmesen kövesse a beépítési útmutatót!
Szerelőbak használata megkönnyíti az összeszerelést.
Az éles szélek sérülést okozhatnak, ezért használjon védőkesztyűt az összeszerelésnél.

Minden Eclisse termék minőségellenőrzésen esik át forgalomba kerülés előtt.

HR

Pazljivo slijedite upute.
Za pravilnu montažu, koristite odgovarajući alat kao što je navedeno, a za postizanje pravilnog ergonomskeg položaja, montirajte dijelove na odgovarajuće nosače. Površine pojedinih sastavnih dijelova mogu biti zaoštrene. Stoga je potrebno koristiti odgovarajuću zaštitnu opremu i zaštititi područja rada.
"ECLISSE srl" ne preuzima nikakvu odgovornost za štete prouzročene korištenjem koje nije u skladu s ovim uputama.

Svi sastavni dijelovi okova za vrata su ispitani i provjereni u "ECLISSE srl"

FI

Noudata näitä kokoamis- ja asennusohjeita tarkasti.
Kehysten kokoamisessa kannattaa käyttää apuna pukkeja.
Käytä suojakäsineitä, sillä osien reunat voivat olla teräviä.

Kaikki Eclisse-tuotteet tarkastetaan ja testataan tehtaalla ennen toimittamista.

TR

Eğer bu talimatları dikkatle takip ederseniz, montaj ve kurulum için işiniz daha kolay olacaktır.
Çerçevenin montajını yaparken, bir çift kasanın kullanılması çok faydalı olur.
Bazı parçalar keskin kenarlara sahip olabilir, bu nedenle eldiven kullanılmı ve parçaları tutarken daha dikkatli olunmalıdır.

Eclisse'nin tüm ürünleri fabrika çıkışından önce kontrol edildi ve test edildi.

ATTREZZATURA NECESSARIA PER IL MONTAGGIO / TOOLS REQUIRED / EQUIPAMENTOS NECESSÁRIOS PARA A MONTAGEM / NÁŘADÍ POTŘEBNÉ K MONTÁŽI / NÁRADIE POTREBNÉ NA MONTÁŽ / HERRAMIENTAS NECESARIAS PARA EL MONTAJE / BENODIGD GEREEDSCHAP OUTILS NECESSAIRES POUR L'ASSEMBLAGE / NOTWENDIGES WERKZEUG ZUR AUSFÜHRUNG DER MONTAGE / OPRZYRZĄDOWANIE POTRZEBNE DO MONTAŻU / НЕОБХОДИМОЕ ДЛЯ УСТАНОВКИ ОБОРУДОВАНИЕ / ECHIPAMENTE NECESARE PENTRU MONTAJ / PRIPOROČLJIVO ORODJE / SZÜKSÉGES ESZKÖZÖK / ALAT POTREBAN ZA MONTAŽU / TARVITTAVAT VÄLINEET / GEREKLÍ ARAÇLAR

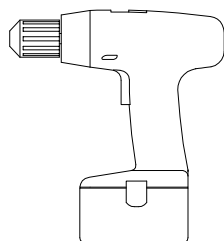
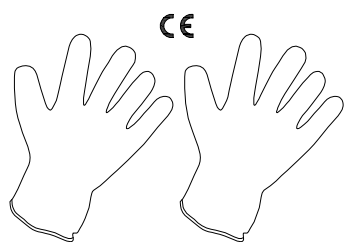

CH. 4 - 2,5

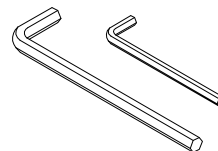

PH2 PZ2

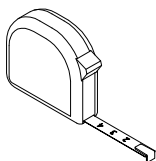
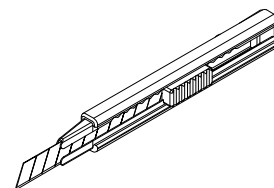
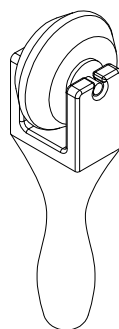

COMPONENTI / COMPONENTS / COMPONENTES / KOMPONENTY / KOMPONENTY / COMPONENTES / ONDERDELEN / COMPOSANTS / BAUTEILE / CZĘŚCI / КОМПОНЕНТЫ / COMPONENTE / SESTAVNI DELI / ALKATRÉSZEK / SASTAVNI DIJELOVI / OSAT / BİLEŞENLER

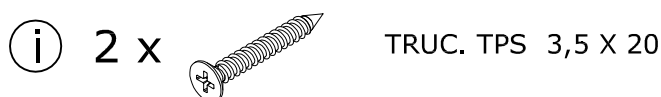
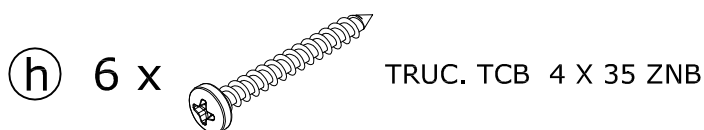
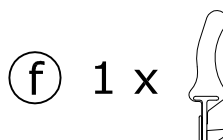
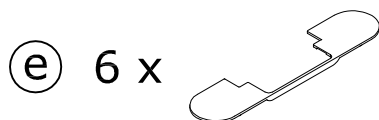
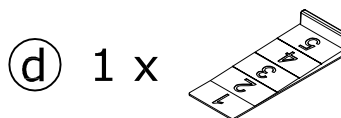
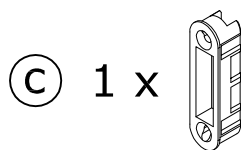
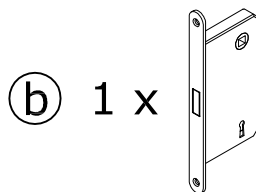
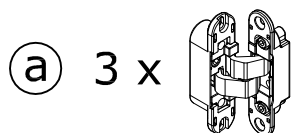

1

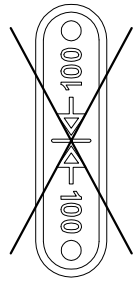
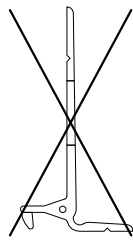
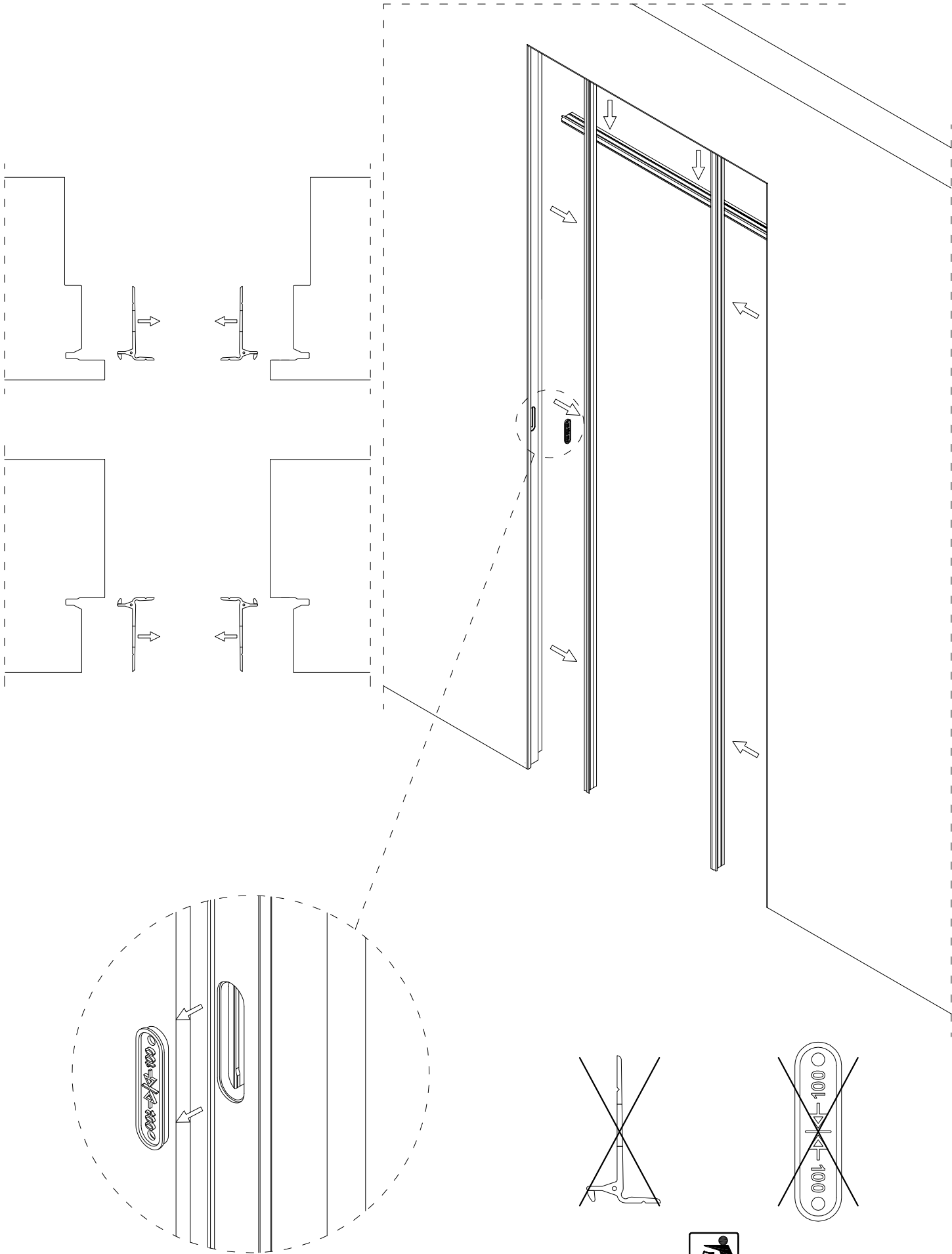

2

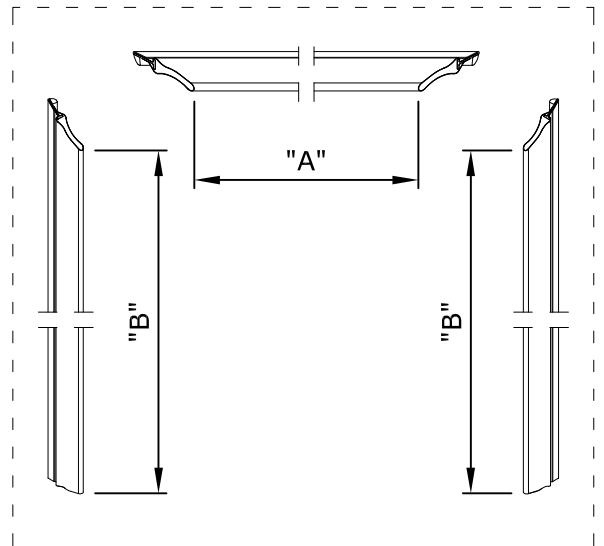
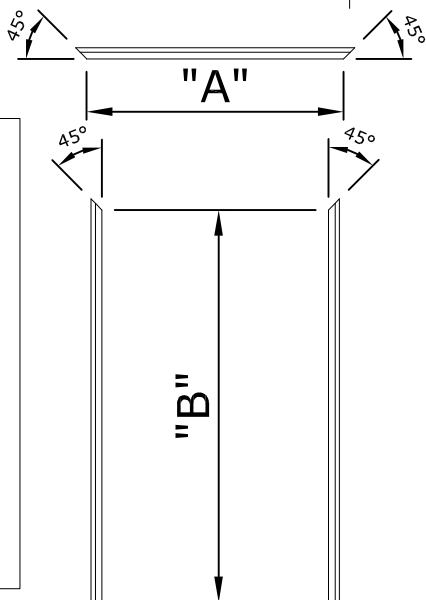
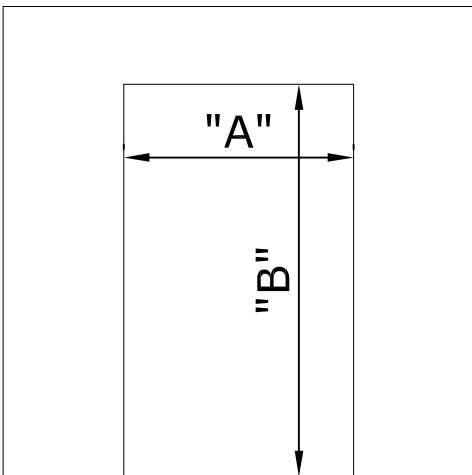
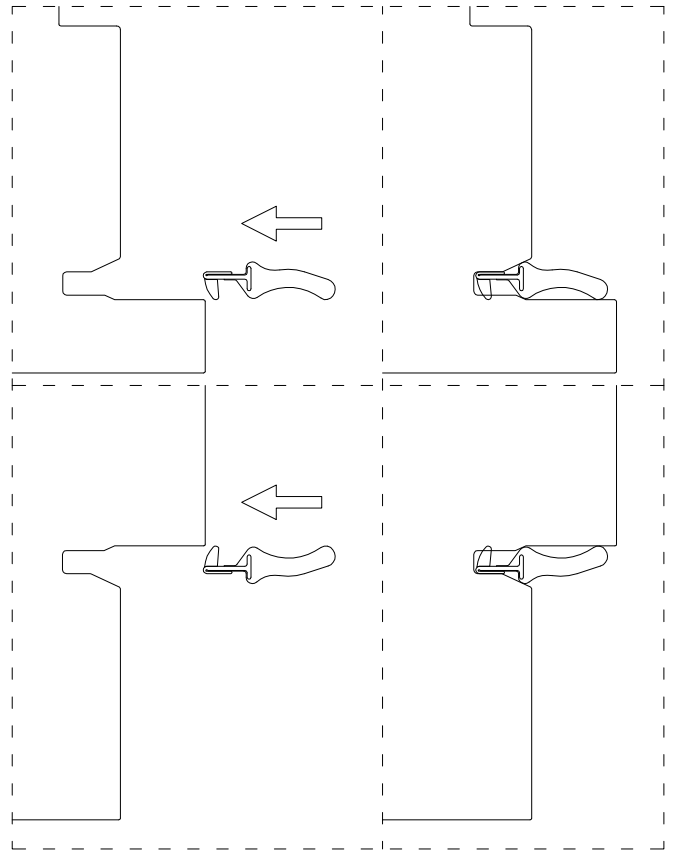
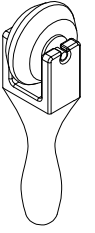
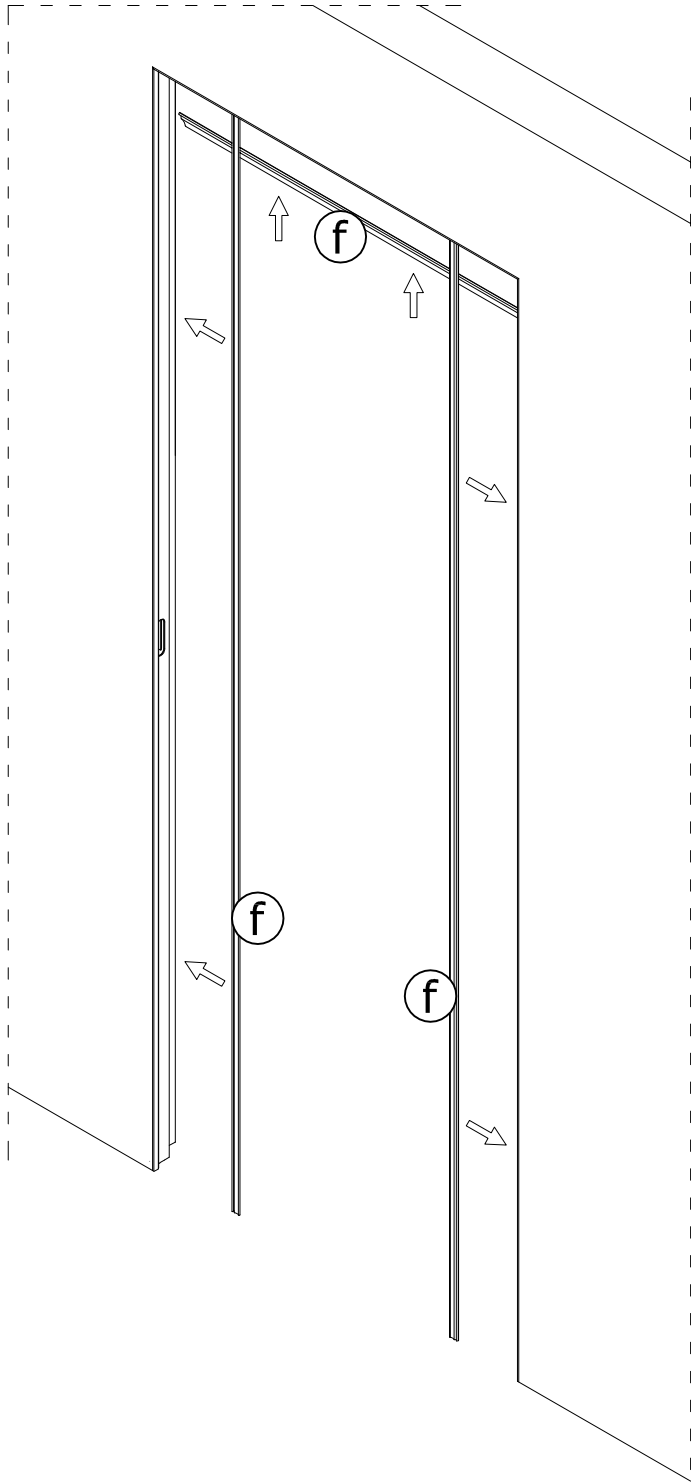

3

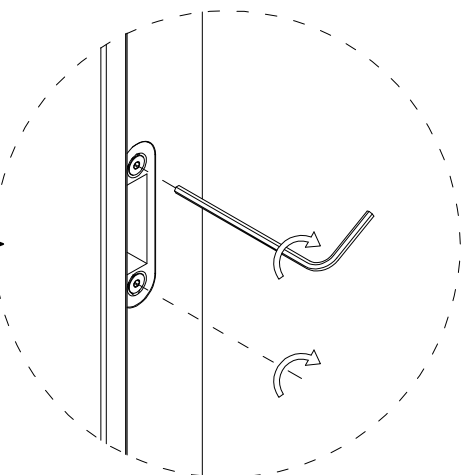
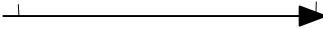
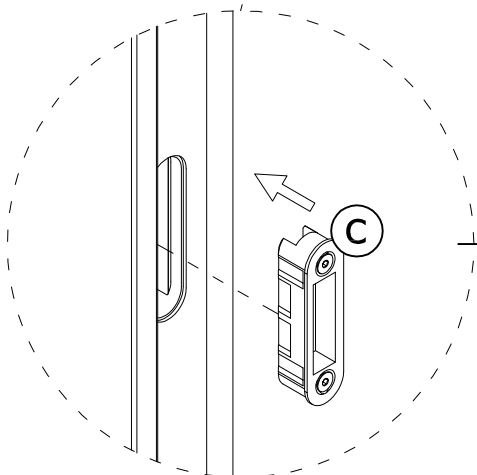
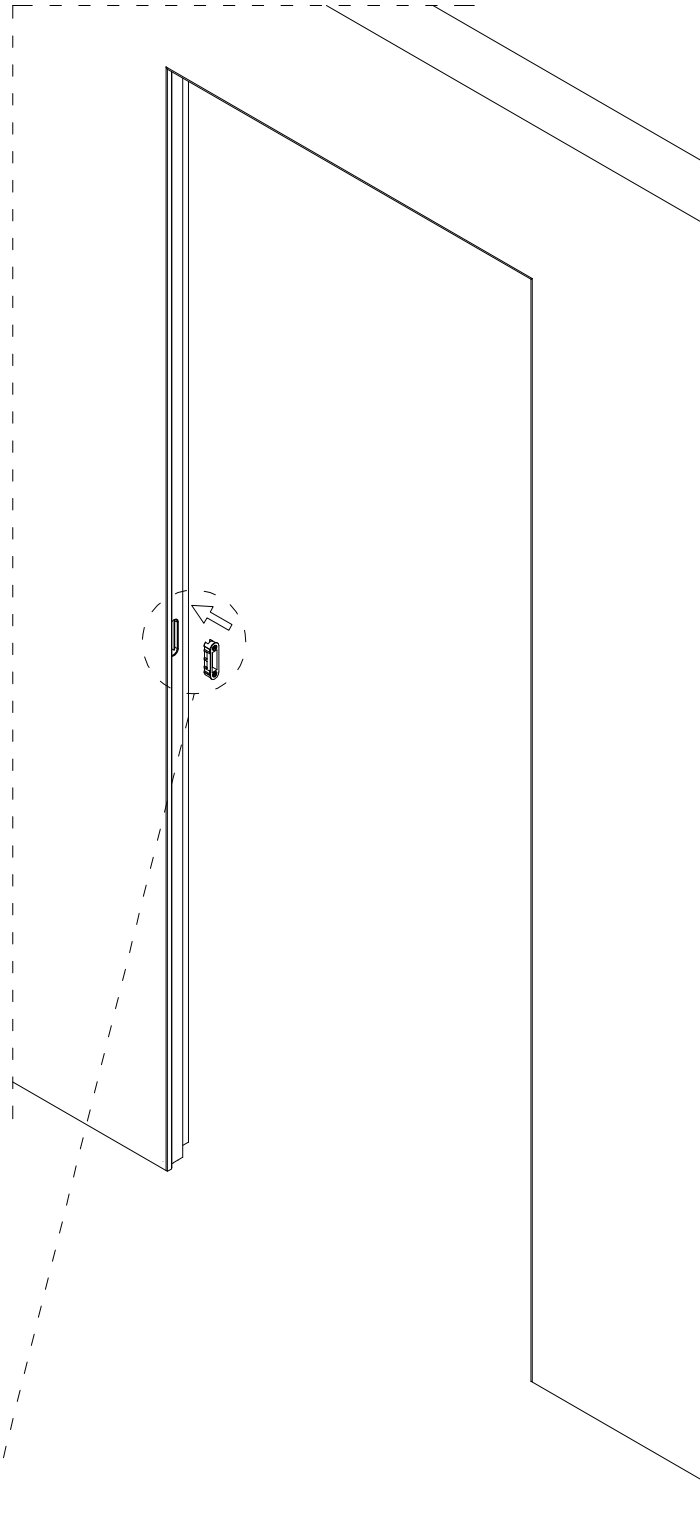

4

Door

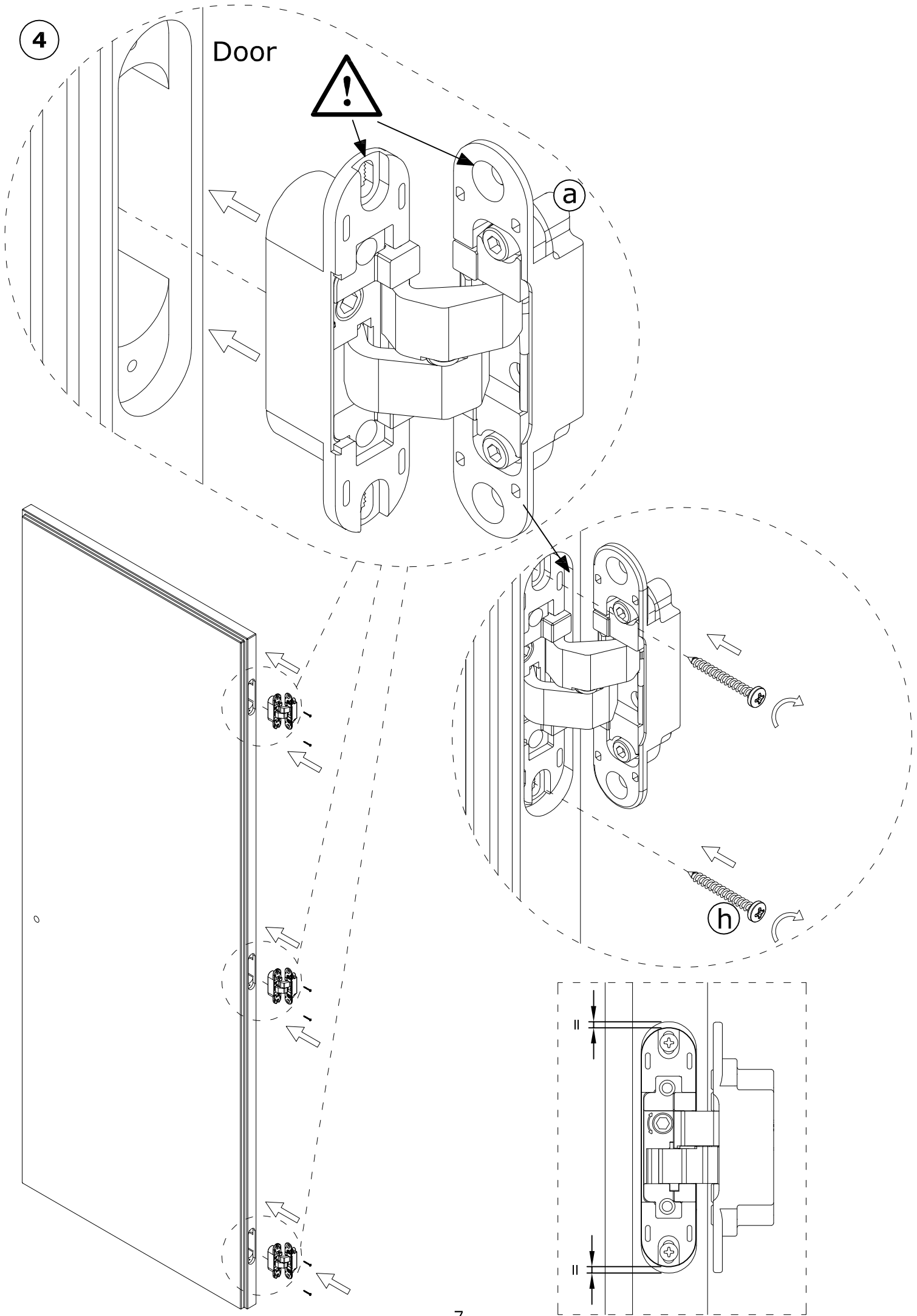

5

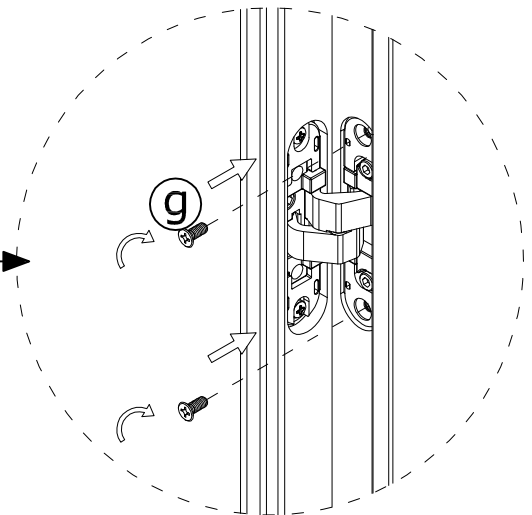
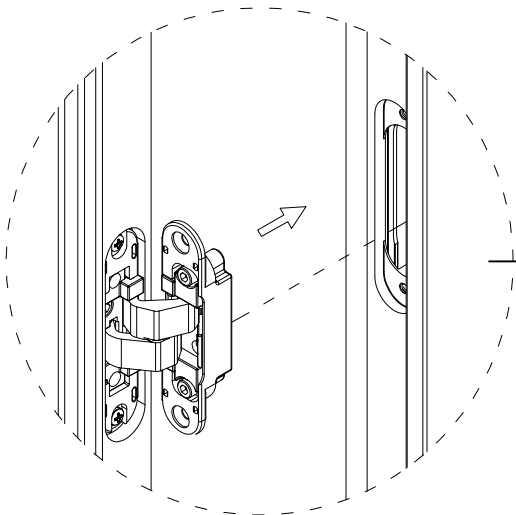
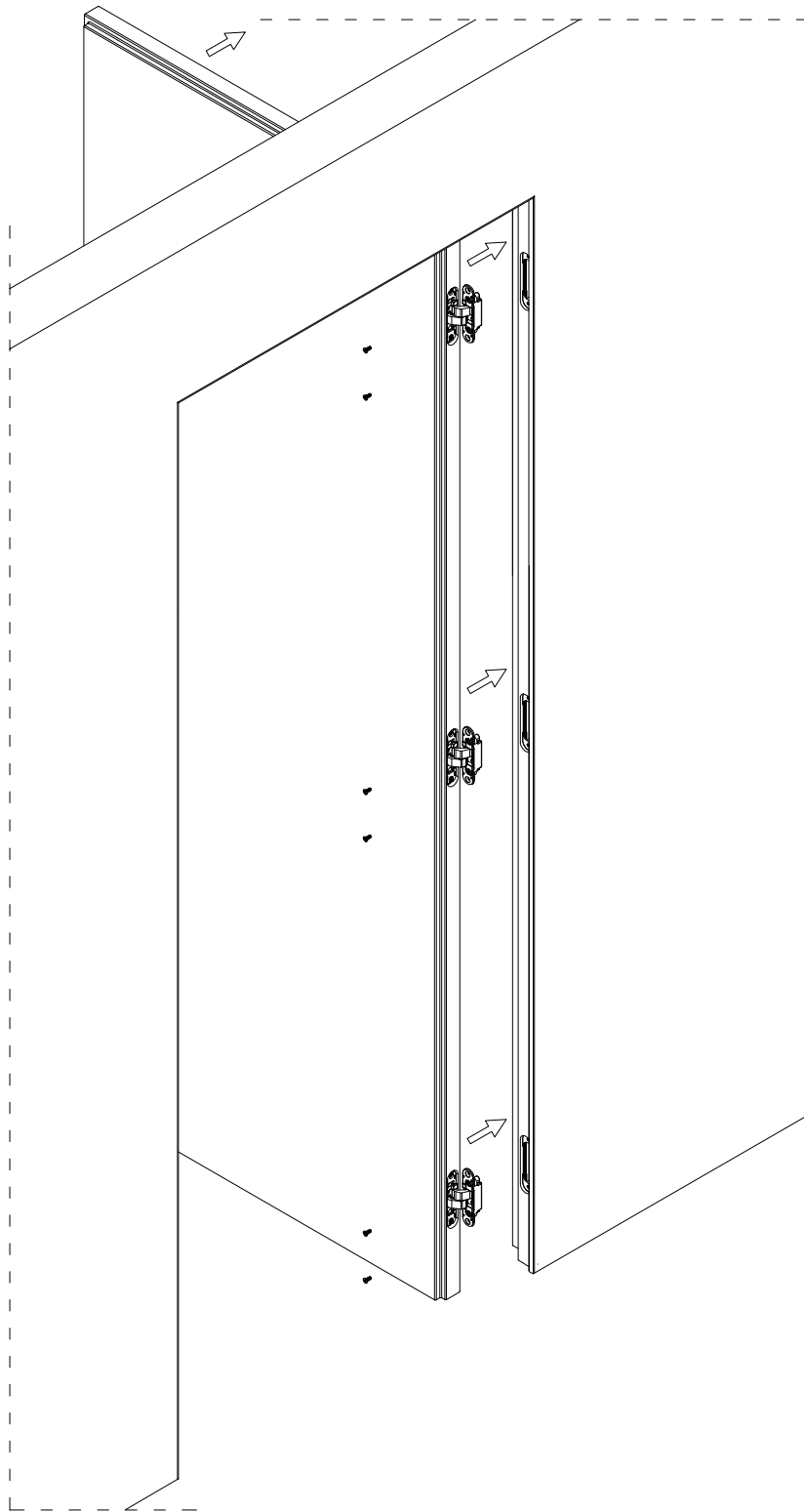

6

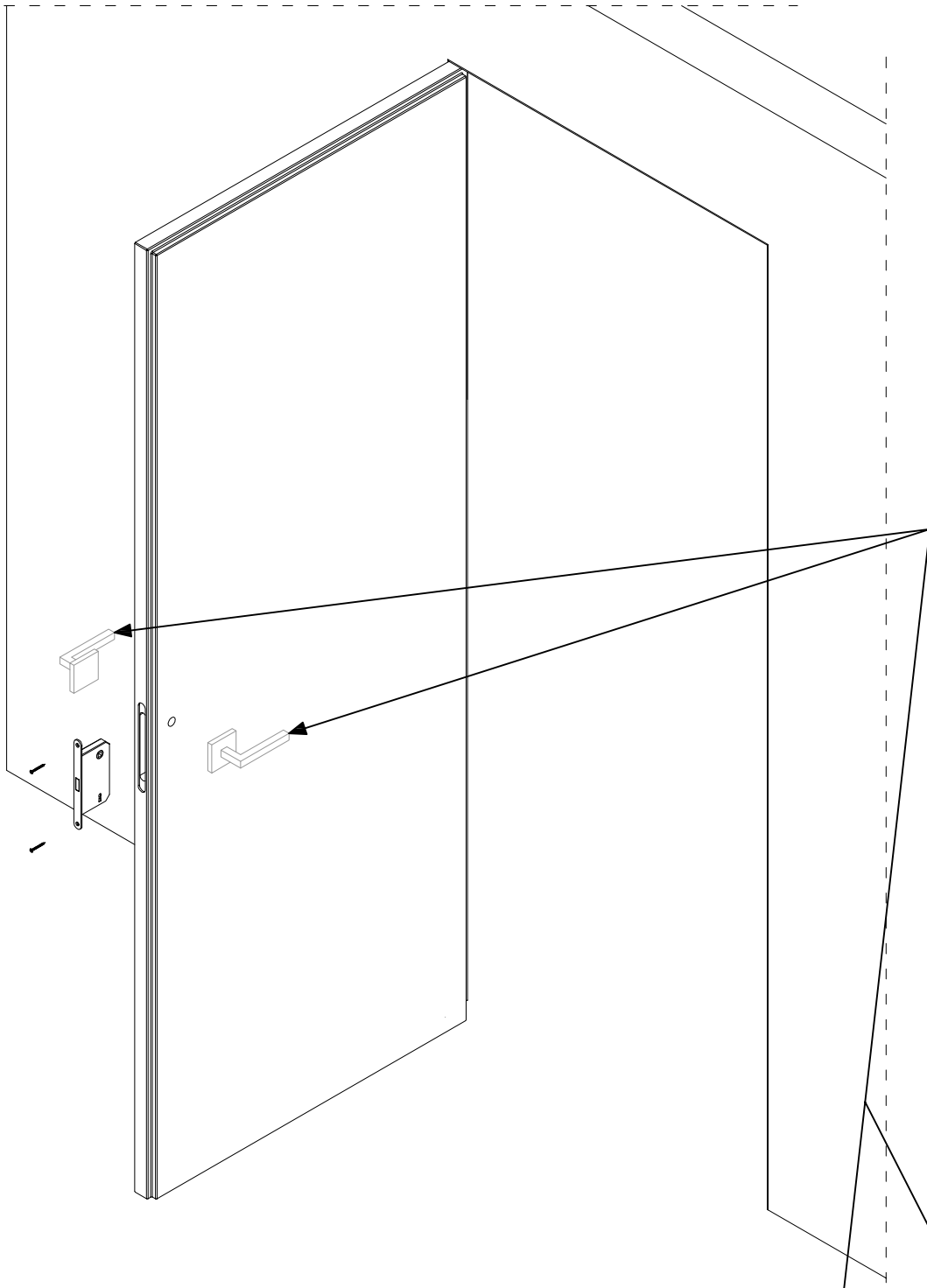

- (IT) PEZZO NON FORNITO
- (GB) NOT SUPPLIED
- (PT) ARTIGO NÃO INCLUIDO
- (CZ) NENÍ SOUČÁSTÍ BALENÍ
- (SK) NIE JE SÚČASŤOU BALENIA
- (ES) PIEZA NO SUMINISTRADA
- (NL) NIET BIJGESLOTEN
- (FR) PIÈCE NON FOURNIE
- (DE) NICHT IM LIEFERUMFANG
- (PL) CZĘŚCI NIE ZABUDOWANE
- (RU) ДЕТАЛЬ НЕ ПОСТАВЛЯЕТСЯ
- (RO) PIEȘĂ NEFURNIZATĂ
- (SI) NI DOBAVLJENO
- (HU) NEM TARTOZÉK
- (HR) DIO KOJI NDE DOSTAVLJEN
- (FI) TOIMITUKSEEN SISÄLTYMÄTÖMÄT OSAT
- (TR) KUTU İÇİNDE YOKTUR

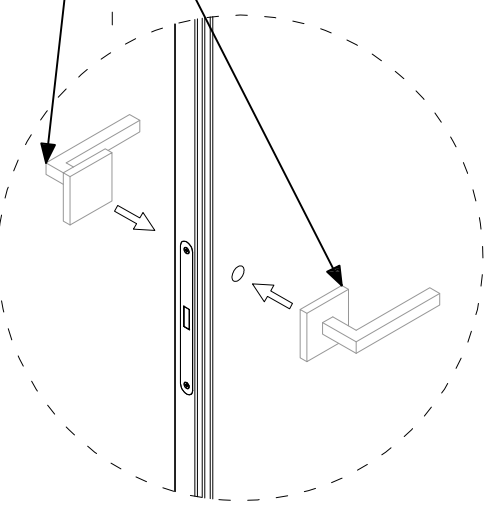
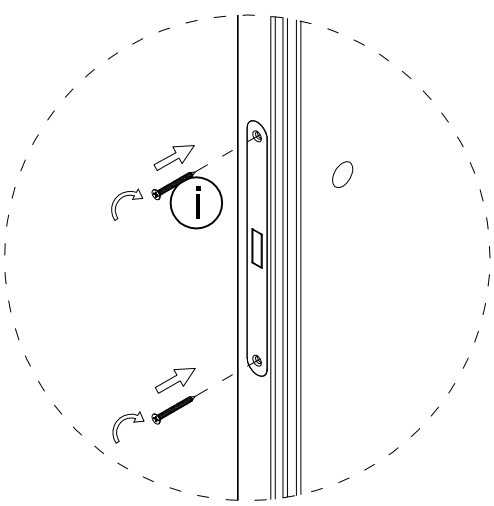
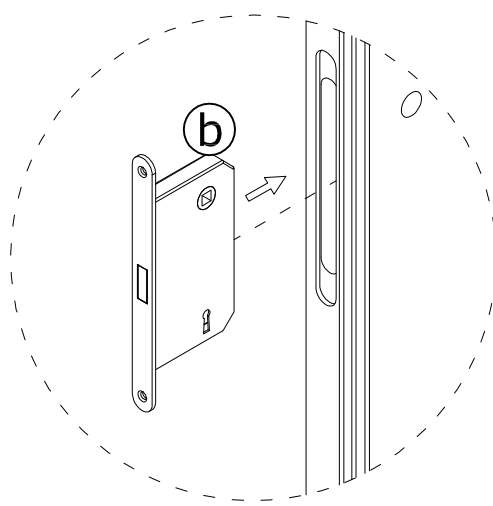

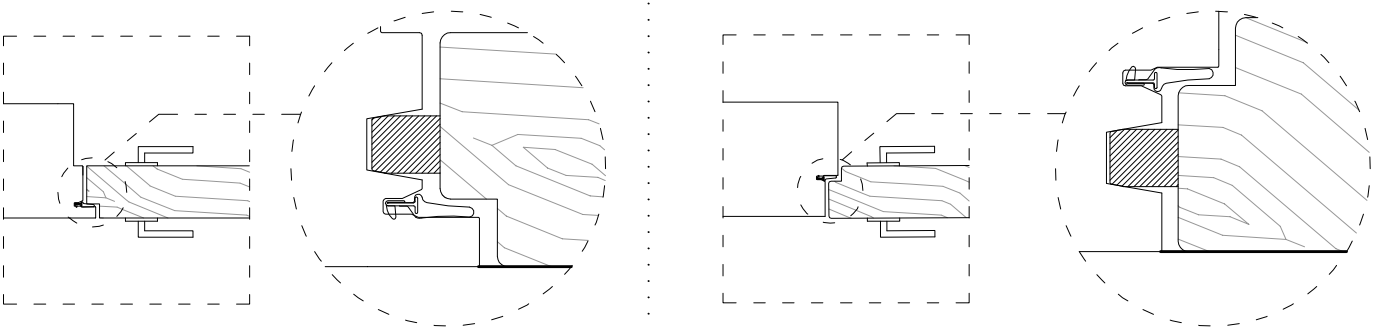
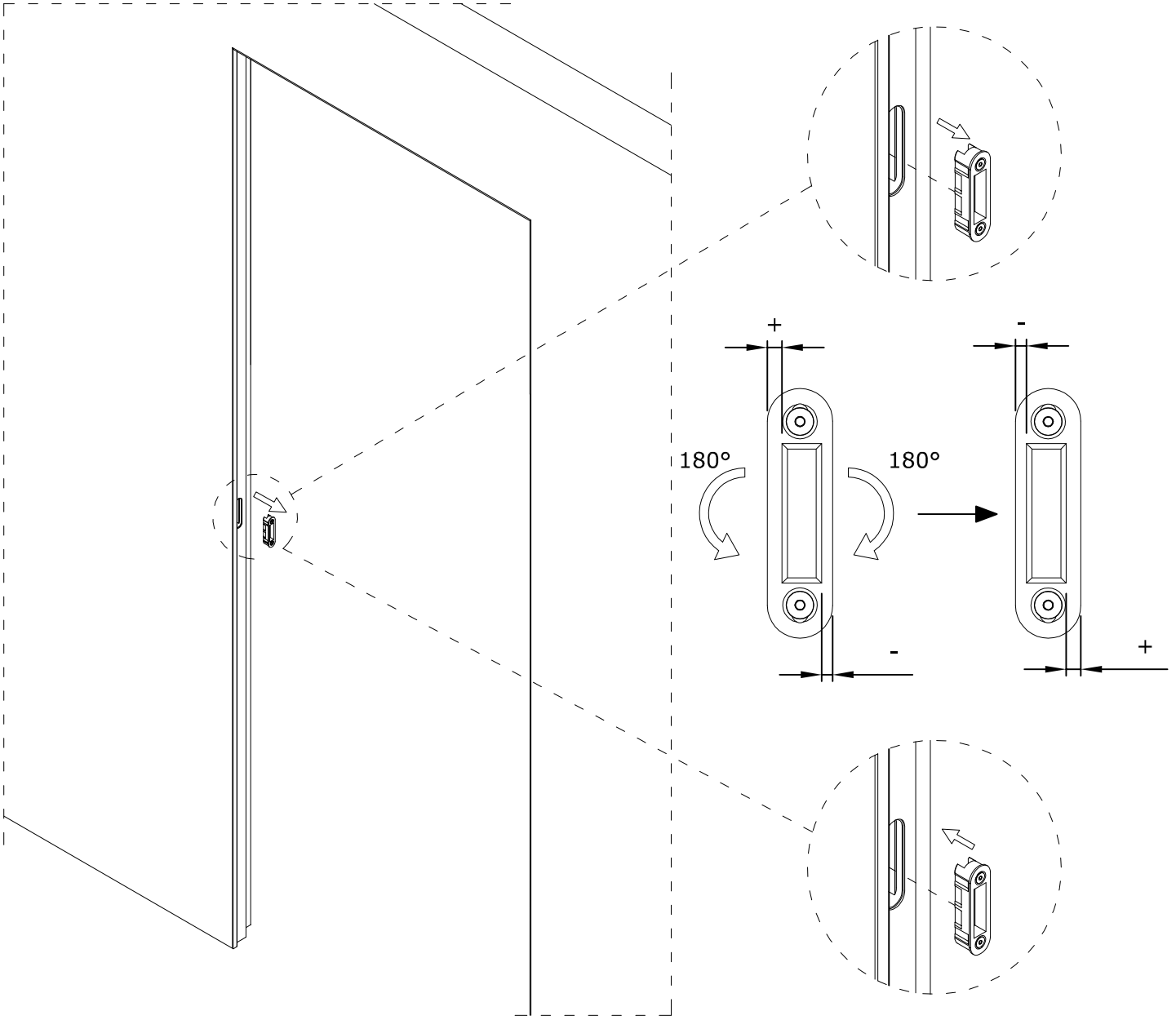
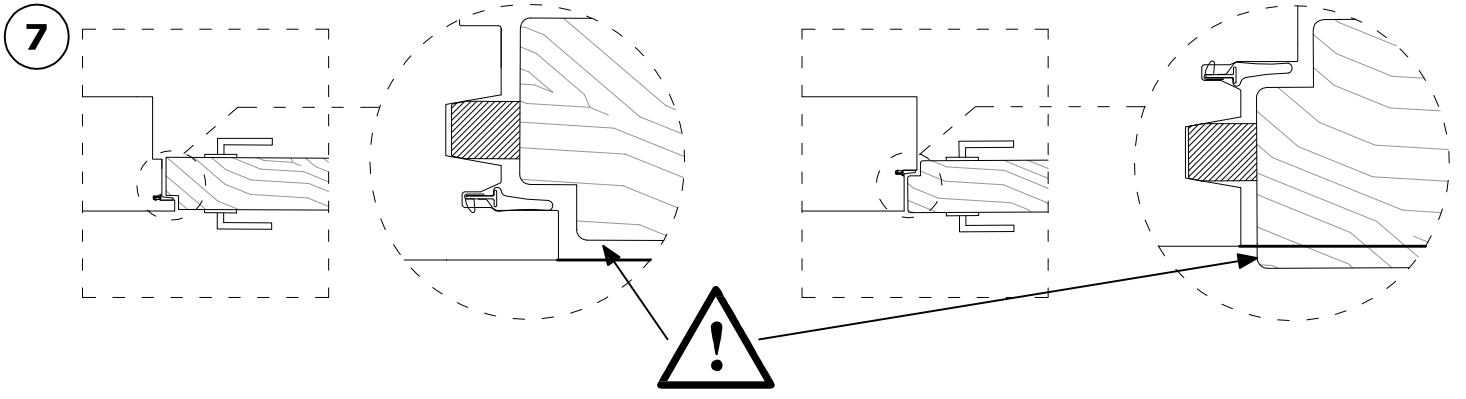

9

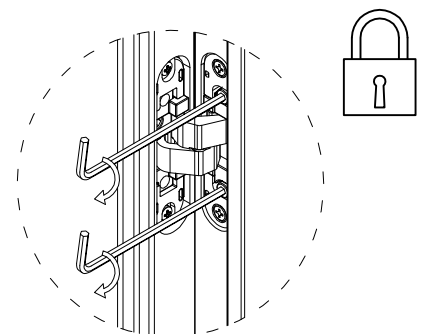
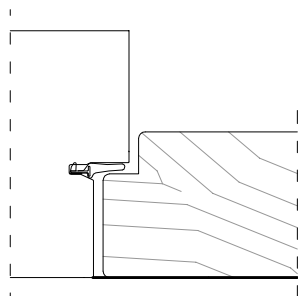
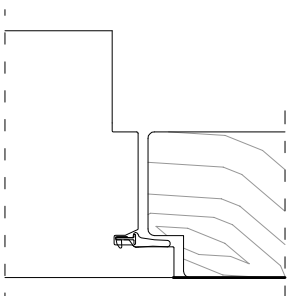
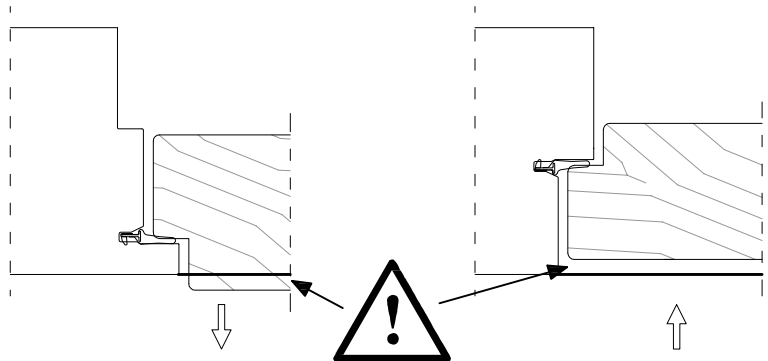
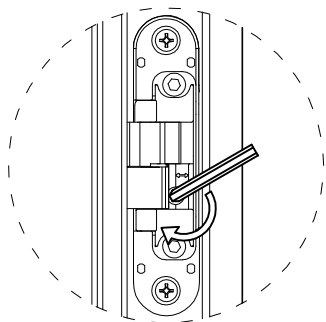
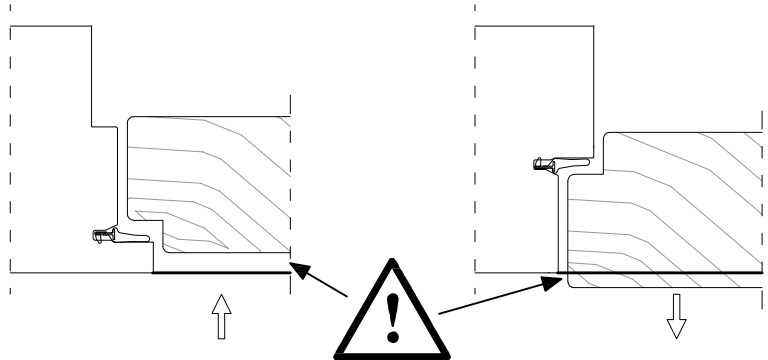
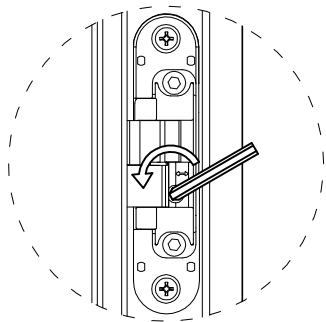
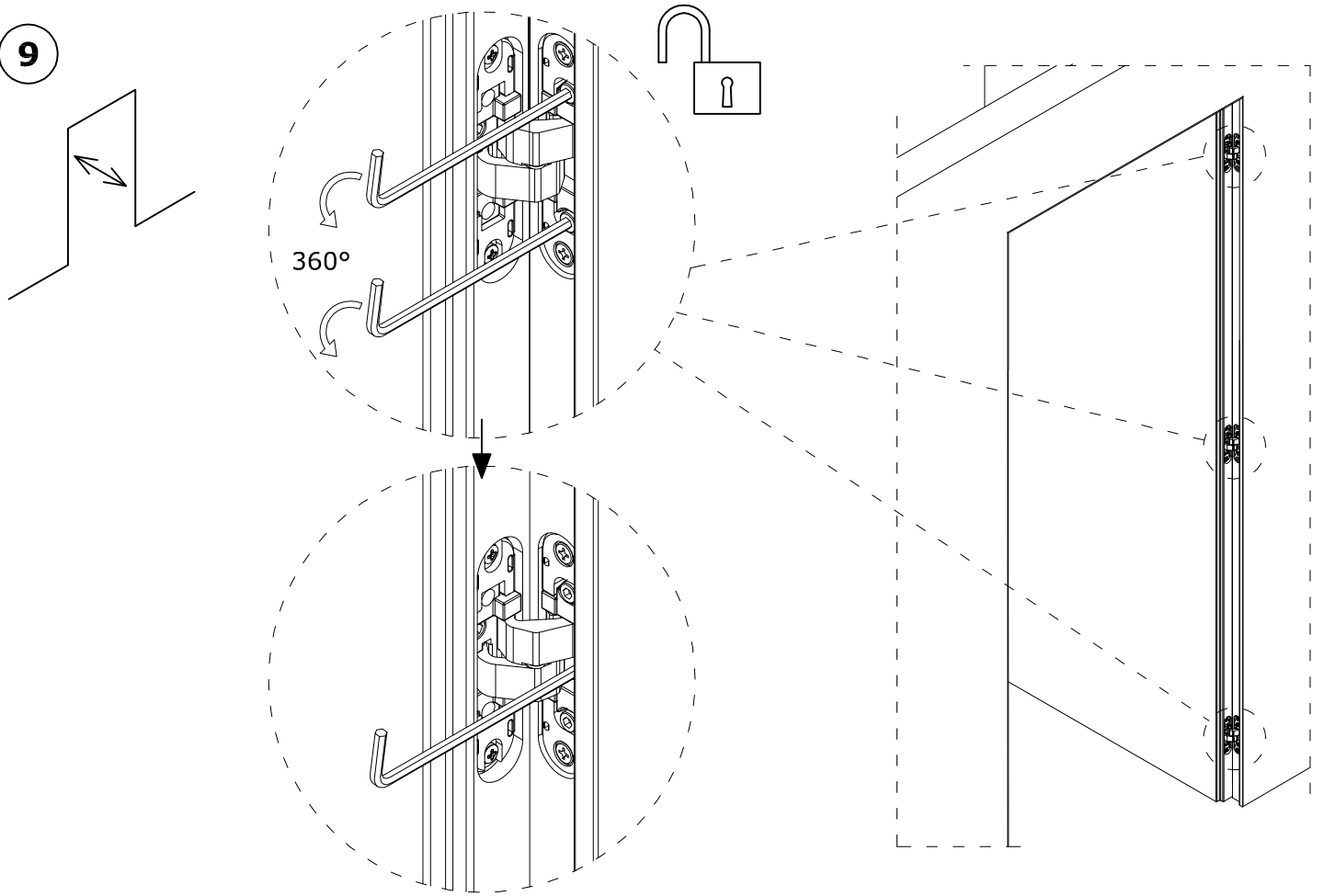

10

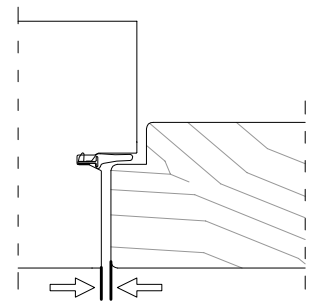
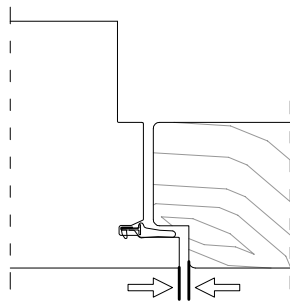
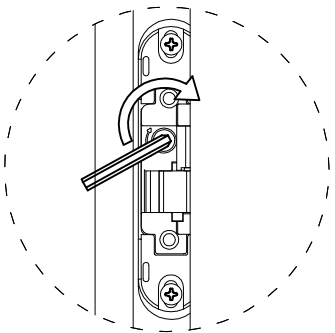
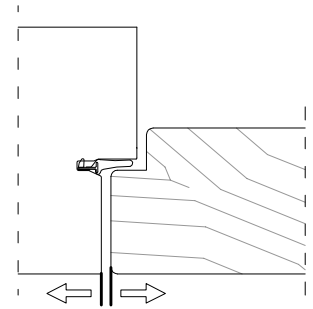
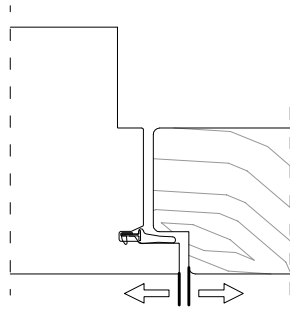
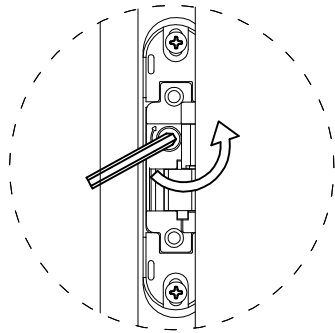
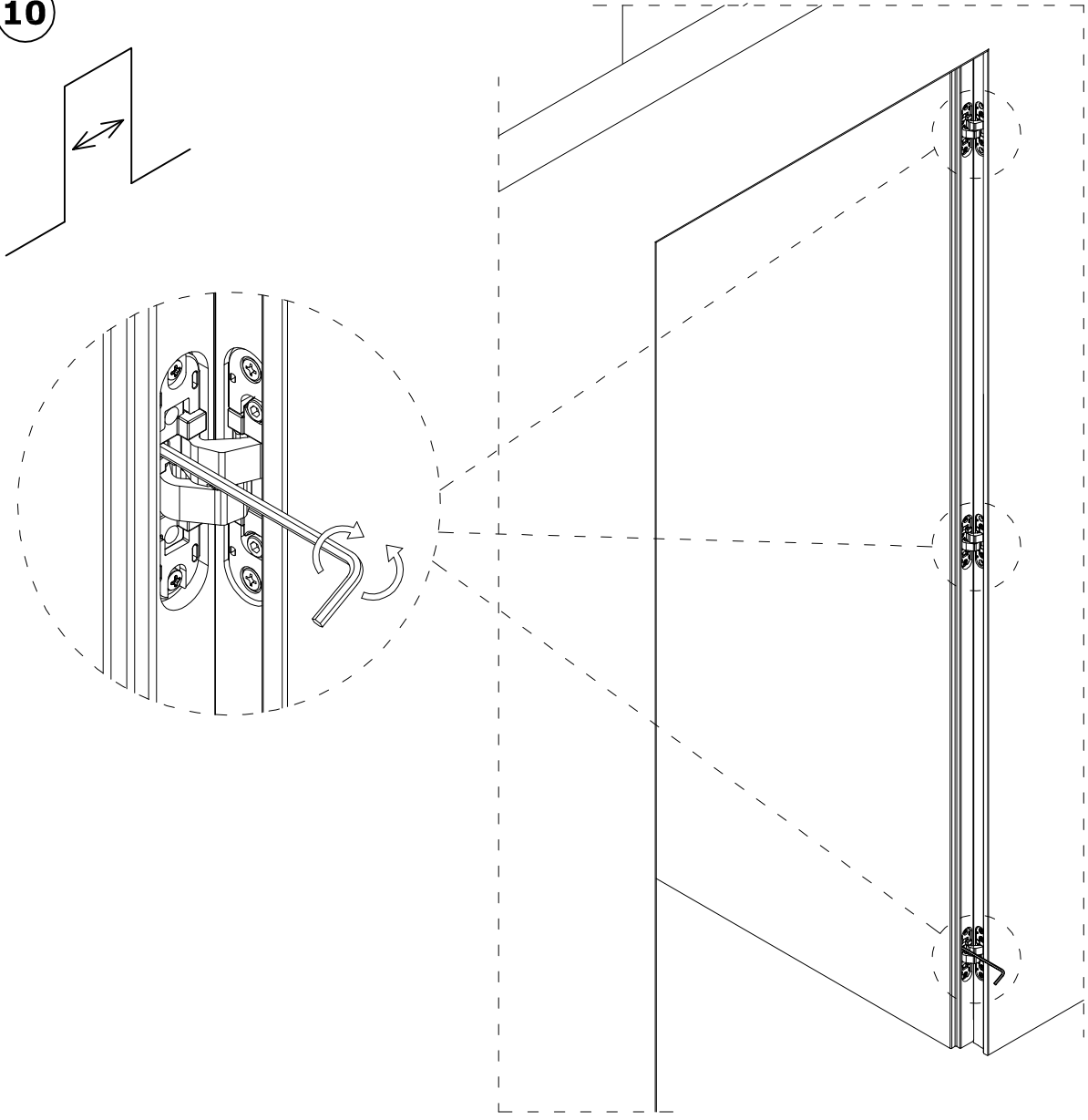

11

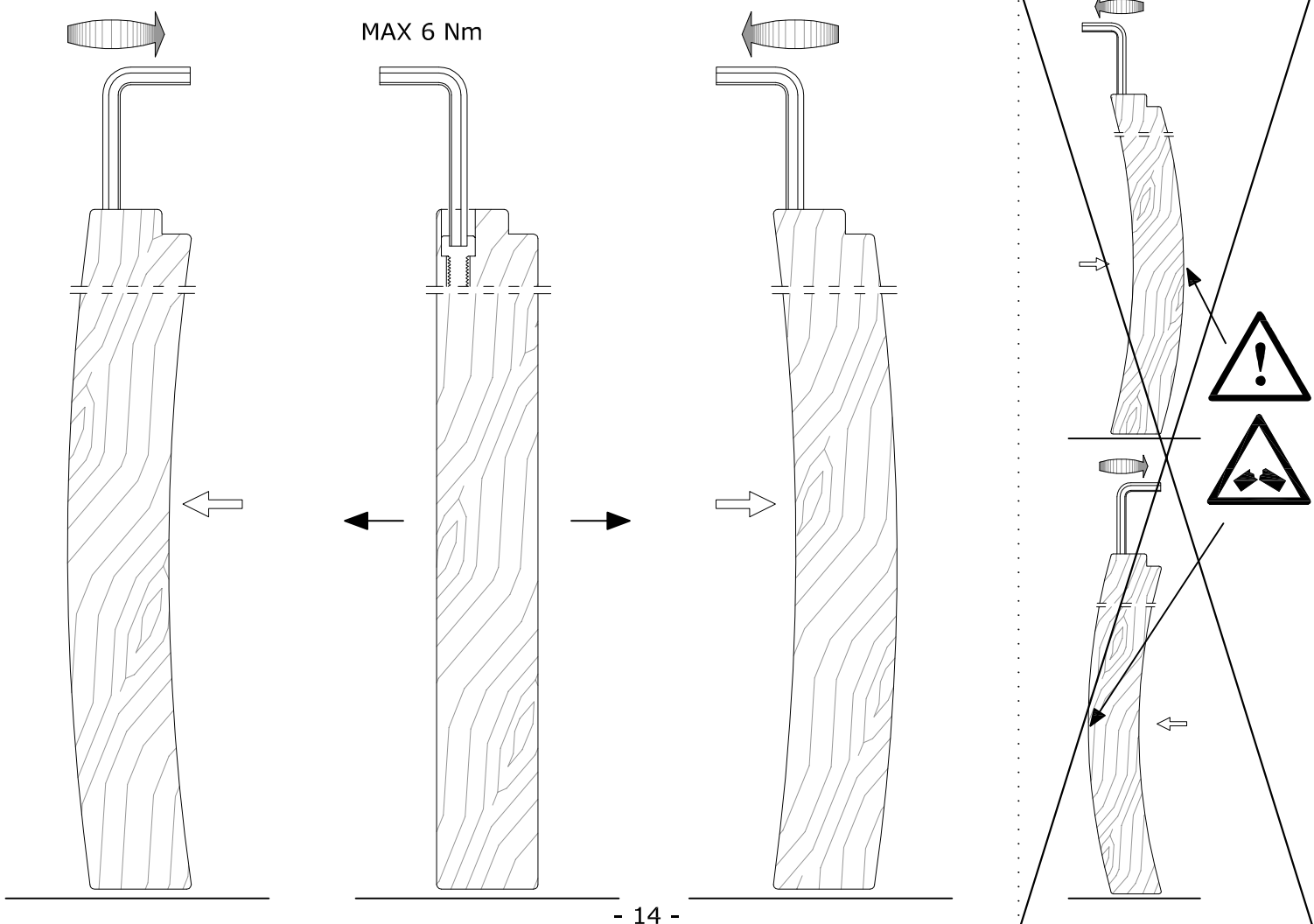
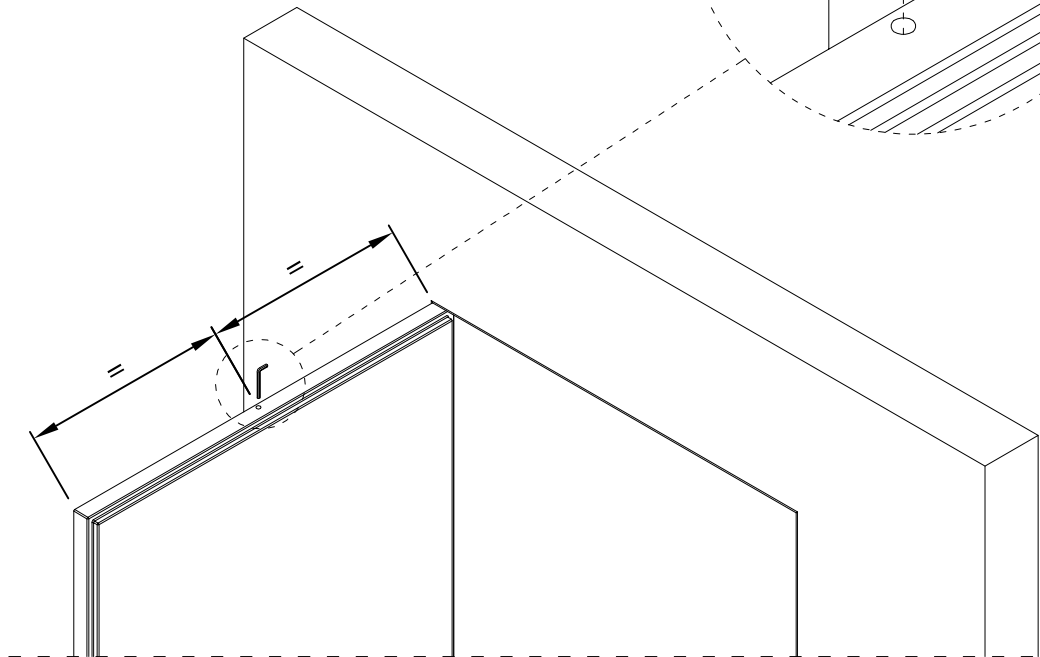
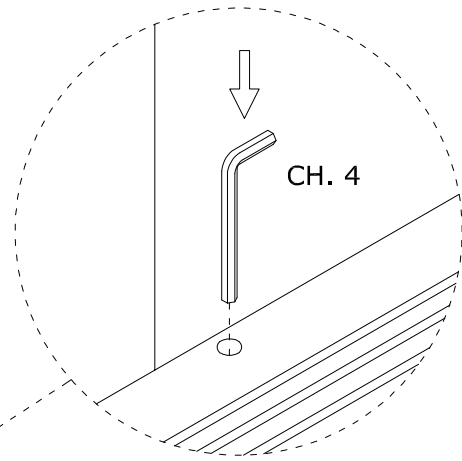
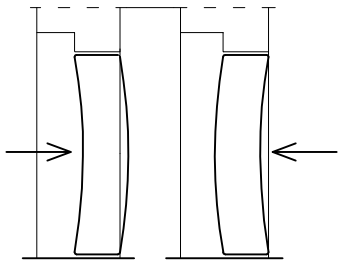

12

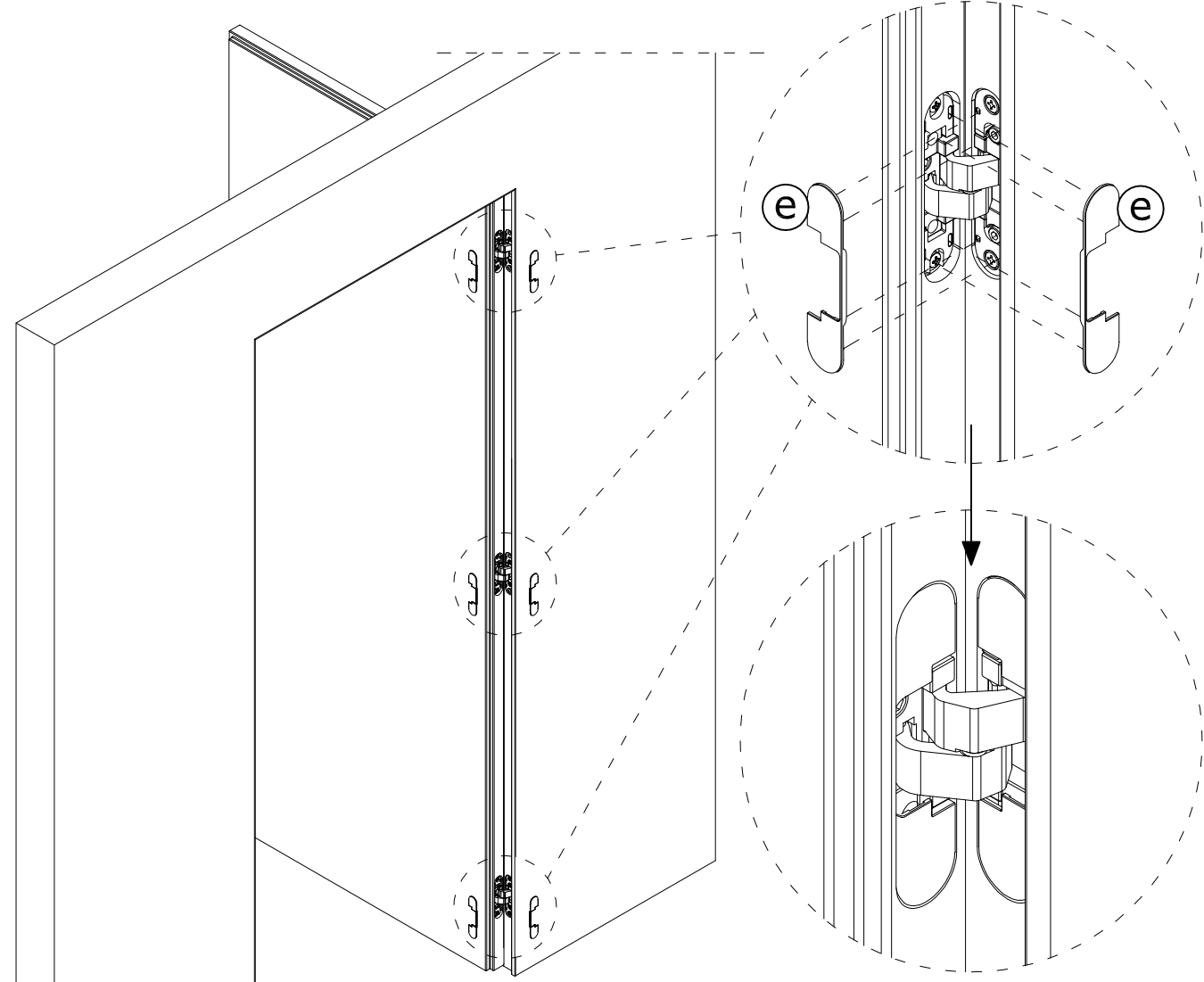

13

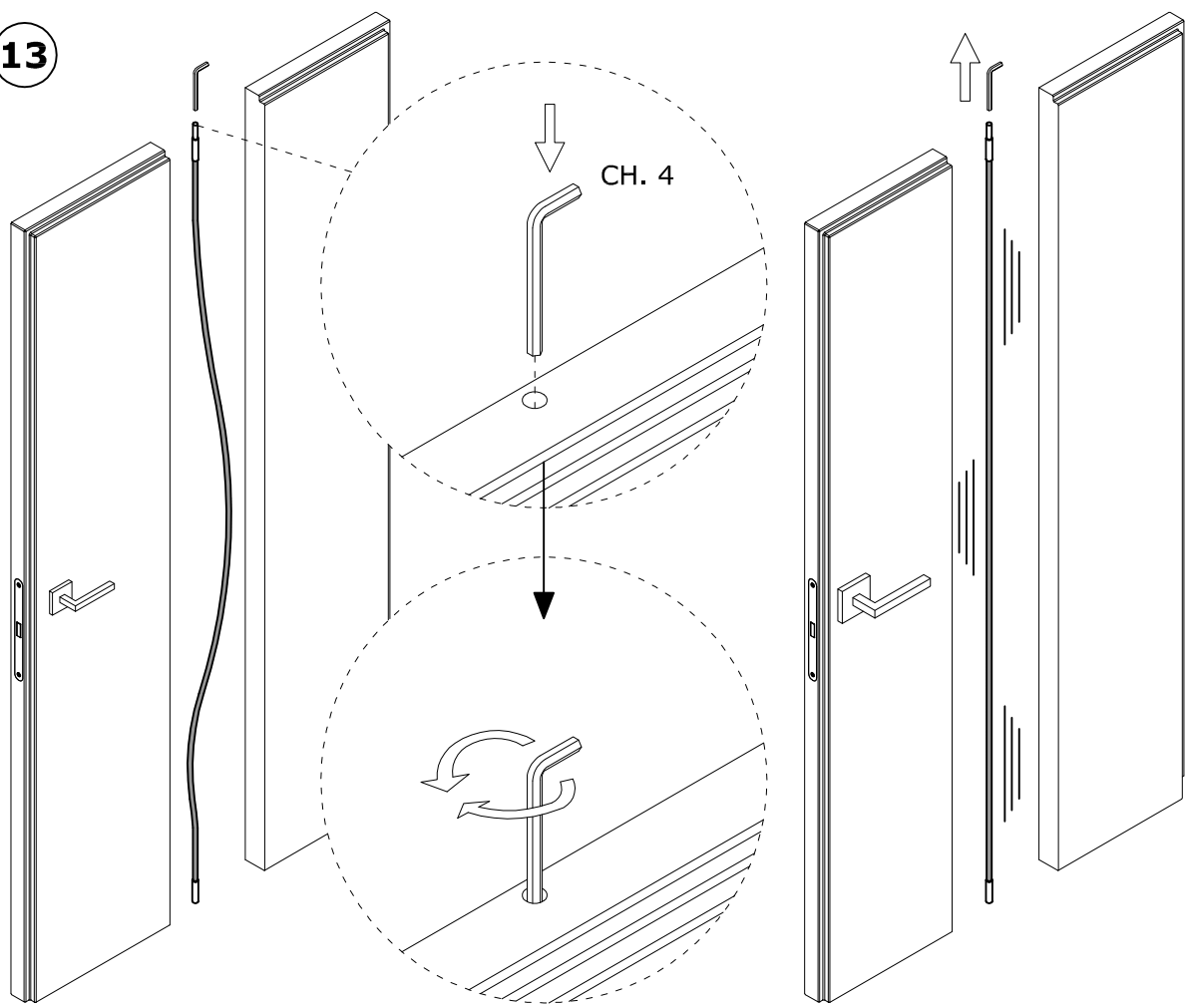

- (IT) METTERE IN TENSIONE IL TIRANTE
- (GB) TIGHTEN THE ROD
- (PT) APORTE A HASTE DA PORTA COLOCANDO-A EM TENSÃO
- (CZ) NAPNUTÍ TÁHLA
- (SK) NAPNITE NAPÍNACIE TIAHLO
- (ES) TENSAR EL TIRANTE
- (NL) SPAN DE STALEN PEN
- (FR) METTRE LA TIGE METALLIQUE EN TENSION
- (DE) DIE ZUGSTANGE ANSPANNEN
- (PL) PROSTOWNIK SKRZYDŁA
- (RU) НАТЯНУТЬ ТЯГУ
- (RO) TENSIONATI TIRANTUL DE PLANEITATE
- (SI) ZATEGNITE NAPENJALNO ŽICO
- (HU) FESZÍTÉSSEL KIEGYENESÍTENI A GÖRBÜLT AJTÓLAPOT
- (HR) ZATEGNITE ŽICU U VRATIMA
- (FI) KIRISTÄ VAJERI
- (TR) KAPI AHSABININ DÖNMESİNİ ENGELLEYEN TELİ GERİN

14

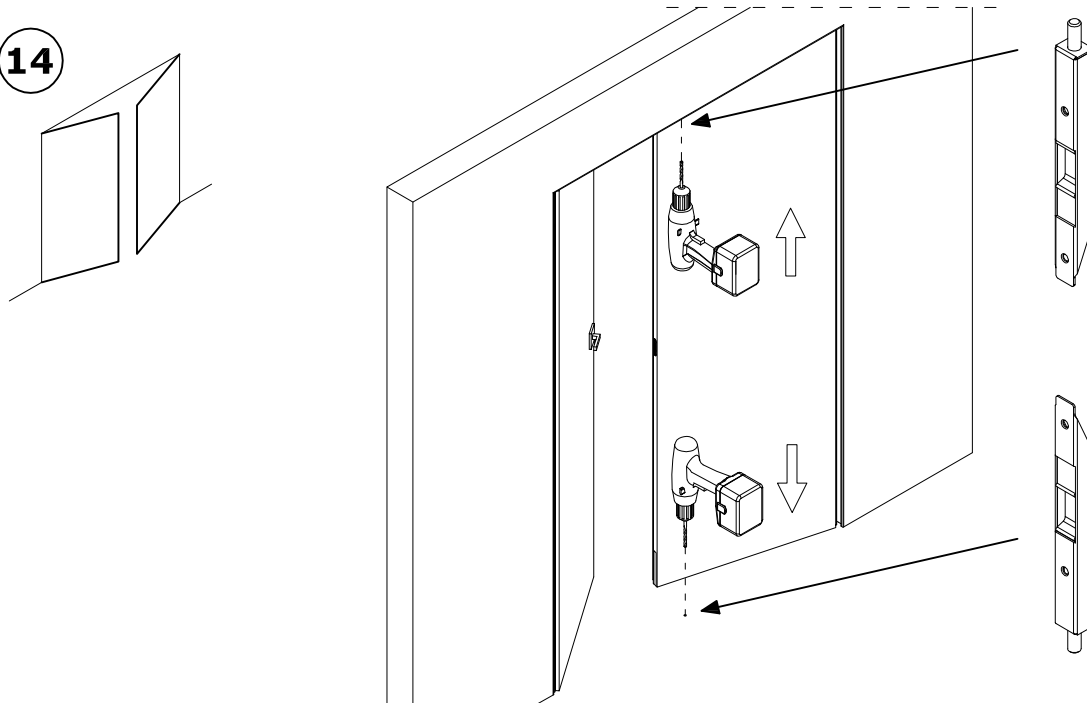

603022804



IT ECLISSE s.r.l. - Tel.:0438 980513 - Fax:0438 980 804 - eclisse@eclisse.it - www.eclisse.it

GB ECLISSE UK - Tel.:0044 845 4811977 - Fax:0044 1476 560710 - info@eclisse.co.uk - www.eclisse.co.uk

PT ECLISSEDOOR - Tel.:00351 912 934509 - info@eclisse.com.pt - www.eclisse.com.pt

BR ECLISSE BRASIL LTDA - Tel:0055 27 3369 6200 - contato@eclisse.com.br - www.eclisse.com.br

CZ ECLISSE ČR s.r.o. - Tel.:00420 286888913 - Mobll:00420 603453645 - Info@eclisse.cz - www.eclisse.cz

SK ECLISSE SLOVAKIA S.R.O. - Tel.:00421 48 4160700 - Fax:00421 48 4160701 - eclisse@eclisse.sk - www.eclisse.sk

ES ECLISSE IBERIA, SL - Tel.:0034 902 550878 - Fax:0034 902 550879 - eclisse@eclisse.es - www.eclisse.es

NL MARSICA SPECIAL DOORS & FRAMES B.V. - Tel.:0031 71 4050050 - Fax:0031 71 4050051 - Info@marsica.eu - www.marsica.eu

FR ECLISSE FRANCE SARL - Tel.:0033 298905696 - Fax:0033 298901634 - Info@eclisse.fr - www.eclisse.fr

DE ECLISSE DEUTSCHLAND GMBH - Tel.:0800 33 47 110 - Fax:0800 33 47 111 - Info@eclisse.de - www.eclisse.de

AT ECLISSE WIEN GMBH - Tel.:0043 1 961 65 65 - Fax:0043 1 961 95 90 - eclisse@eclisse.at - www.eclisse.at

PL ECLISSE POLSKA SP. Z.O.O. - Tel.:0048 58 5311995 - Fax:0048 58 5322578 - eclisse@eclisse.pl - www.eclisse.pl

RO ECLISSE EST SRL - Tel.:0040 371 46 60 60 - Fax:0040 372 89 86 82 - info@eclisse.ro - www.eclisse.ro

HU VENETO PORTE PLUSZ KFT - Tel.:0036 30 538 9027 - Fax:0036 2244 1108 - info@eclisse.hu - www.eclisse.hu

FI MUOTOLEVY OY - Tel.:010 2814000 - myynti@muotolevy.fi - www.eclisse.fi

TR HAFELE MOBILYA - Tel.:0090 216 528 59 00 - Fax:0090 216 528 59 30 - www.eclisse.com.tr

TN TECHNOBAT - Tel./Fax:00216 71 942429 - info@technobat.com.tn - www.technobat.com.tn

US EURO ARCHITECTURAL, LCC - Tel.:001 800 614 1474 - info@euro-arch.com - www.eclisse.us

RU VISHERA-GROUP -Tel. 007 495 518 96 89; Fax: 007 495 518 96 95 - a_malofeev@vishera-group.ru - www.vishera-group.ru

SE GÖTHES INDUSTRIBESLAG AB - Tel. 0046 010 4834000 - ab@gothes.se - www.gothes.se

DK SCANDISOLUTION APS - Tel. 0045 6467 3469 - info@scandisolution.dk - www.scandisolution.dk

CH LINEAR SYSTEM GMBH - Tel. 071 660 08 40 - Fax: 071 660 08 44 - Info@lnearsystem.ch - www.lnearsystem.ch

RS OVOCONCEPT - Tel. 00381 11 616 7608 - office@ovoconcept.rs - www.ovoconcept.rs

SI MIROLJUB TEINOVIC (AGENT) - Tel. 00386 4 1333229 - Fax: 00386 5 7655210 - miro.teinovic@siol.net

GR VALANTIS GRAMMENPOULOS (AGENT) - Tel. 30 2310 403844 - Fax: 30 2310 403845 - vgrammenopoulos@gmail.com

www.eclisseworld.com

